

EvoPEX

Lose Nut Connectors

Scope of Use / Specification Sheet

Proudly made in Australia, the EvoPEX system is an evolutionary step in providing an advanced potable water system for safe and efficient water delivery. EvoPEX is an innovative push-to-connect fitting designed for the modern day plumber, ideal for residential or commercial plumbing applications. Engineered as a more efficient alternative to tool-based pipe joining methods, EvoPEX improves efficiency, minimizes lost time on the job and mitigates risk.

EvoPEX is suitable for use with PEX pipe utilizing push-to-connect fitting system technology for a permanent connection.



Product Code

| Code | Size |
|---------|----------------|
| 1544906 | 16mm x 1/2" FI |
| 1544907 | 20mm x 3/4" FI |

The Unique EvoPEX 'Green' Protection Ring Provides 3 Functions

- It's location in front of the radial seal provides protection against foreign matter entering the fitting.
- The protection ring has a face chamfer that helps guide the PEX pipe over the radial seal during insertion. The chamfer design eliminates the need for the PEX pipe to be deburred.
- The EvoPEX 'green' protection ring provides a visual indication for the installer that the PEX pipe has been inserted to the correct depth and a secure joint has been achieved.

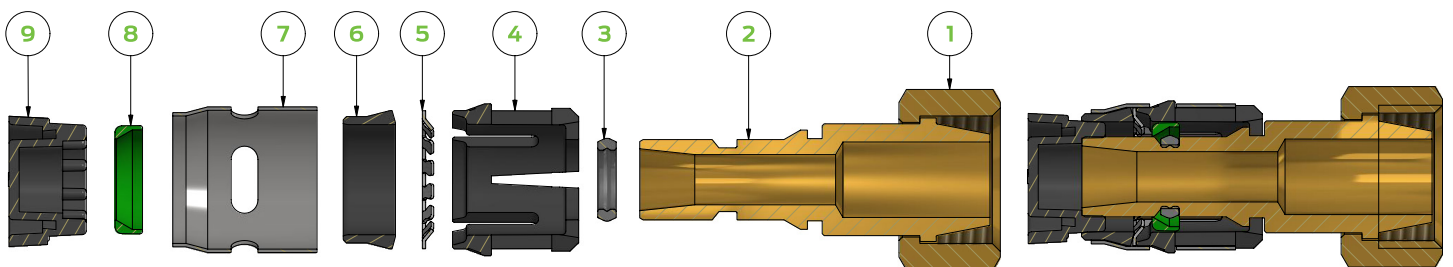

Materials

| | | | | | |
|-----------------|------------|-------------|-----------|-------------------|-----------|
| 1 Body | DZR Brass* | 4 Collet | Grilamid | 7 Collet Retainer | SST 304 |
| 2 Connector Nut | DZR Brass* | 5 Grab Ring | SST 316 | 8 Protection Ring | Copolymer |
| 3 Radial Seal | EDPM | 6 Spacer | Copolymer | 9 Protection Cap | LPDE |

*Lead Free fitting with surfaces that are in contact with consumable water containing less than 0.25% lead by weight.

EvoPEX Lose Nut Connectors

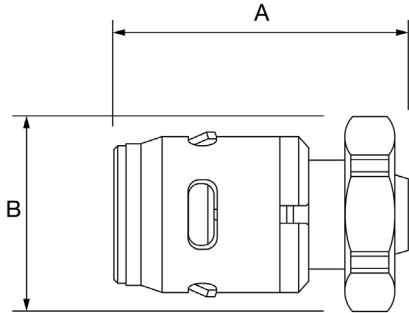

Dimensions

| Code | Size | A | B | Pipe Insertion Depth |
|---------|----------------|-------|-------|----------------------|
| 1544906 | 16mm x 1/2" FI | 53.80 | 26.90 | 16 = 21.107 |
| 1544907 | 20mm x 3/4" FI | 54.90 | 31.20 | 20 = 24.003 |

Note: All measurements in mm unless otherwise stated.

Maximum Working Pressure

PEX pipe manufactured to AS/NZS 2492 and designed to operate with a working pressure of 2,000kPa at 20°C can be operated continuously at 70°C with a maximum working pressure of 1,000kPa.

Temperatures above 70°C for any period will affect the life of the pipe.

UV Resistance

The EvoPEX pipe and fittings should not be installed in direct or reflected sunlight as the material may degrade with extended UV exposure. Where external installations is required, install the EvoPEX pre-conduited produce or provide other similar UV protection.

Codes and Standards

Certified to Australian and or New Zealand Standards AS/NZS 4020, AS/NZS 2537.2, AS 2492



CERTIFICATE OF CONFORMITY

Underground Wrapping

| EvoPEX Fitting Body Type | Wrapping |
|--------------------------------|----------|
| EvoPEX – with brass body | Yes |
| EvoPEX – with all polymer body | No |

Protection Caps

It is important that no foreign matter be present within the fitting prior to pipe fitment. A multi purpose protection cap ensures all fittings are free of contamination prior to installation. The protection cap can also be used on the PEX pipe end to ensure the pipe remains free of any onsite materials that may be caught when pushing pipes through frames, under floor or within ceilings. Added protection for your peace of mind.

